

SMA memo 136

Connecting the CSO and JCMT to the SMA

Martina C. Wiedner

March 1999

1 Introduction

Currently there are two submillimeter telescopes on Mauna Kea in Hawaii, the Caltech Submillimeter Observatory (CSO) and the James Clark Maxwell Telescope (JCMT). Soon there will be eight 6-meter antennas which constitute the Submillimeter Array (SMA). The SMA will operate as an interferometer with a collecting area of 226 m^2 and 28 baselines, the longest of which is about 500 m. The CSO and JCMT are generally operated as single dish antennas. However, the two telescopes have previously been operated as a two element interferometer with a single baseline of 164 m, allowing observations between 180 and 650 GHz. The obvious next step is to connect all submillimeter antennas on Mauna Kea to make an interferometer consisting of all submillimeter telescopes on the site. This will almost double the collecting area to 488 m^2 , increase the number of baselines to 45 for better imaging, and the longest baseline will nearly reach 770 m, hence yielding higher sensitivity, easier self calibration and higher spatial resolution.

This report outlines a general scheme to allow interferometric observations with the three observatories. It intends to continue the discussion about how to connect the antennas and to stimulate specific work to make submillimeter observations with high resolution and high sensitivity possible in the near future.

2 Technical description of CSO-JCMT-SMA interferometer

The general concept is to add the CSO and the JCMT to the SMA as if they were two additional antennas of the SMA. The CSO and JCMT will be controlled from the SMA control room, their IF signals will be sent back to the SMA correlator. This will require software to steer the CSO and JCMT from the SMA as well as to monitor the receiver status (§2.1). In addition the CSO and JCMT local oscillators will need to be locked to the SMA oscillators (§2.2.5) and the returned intermediate frequency will need to match (§2.2.4). Ideally the joint interferometer will be able to observe between 180 and 920 GHz. Since the CSO and the JCMT are set up to use only one receiver at a time, the joint array will at least initially only support single-frequency observations.

Fig. 1 shows the proposed overall plan. On the left are the parts of the CSO/JCMT which will be used in the joint submillimeter interferometer. The center section shows electronics which will be added to the two antennas to provide a link to the SMA. The right section shows electronics and correlator in the SMA control room that will be connected to the CSO/JCMT.

2.1 Antennas and control

2.1.1 Computer link

A computer link is needed between the CSO/JCMT and the SMA control room. Since the CSO-JCMT interferometer operation showed that the ethernet link on Mauna Kea is not sufficiently reliable, it is suggested to connect the telescopes with the control room by a dedicated multimode fiber. Reflective memory cards will be installed on both ends of the fiber. A set of two reflective memory cards contains exactly the same files, wherever modifications of the files occur the other card is immediately updated. The CSO/JCMT will have the latest commands from the control room on its reflective memory, and the receiver status will be updated automatically on the reflective memory card in the SMA control building.

Connection of CSO and JCMT to SMA

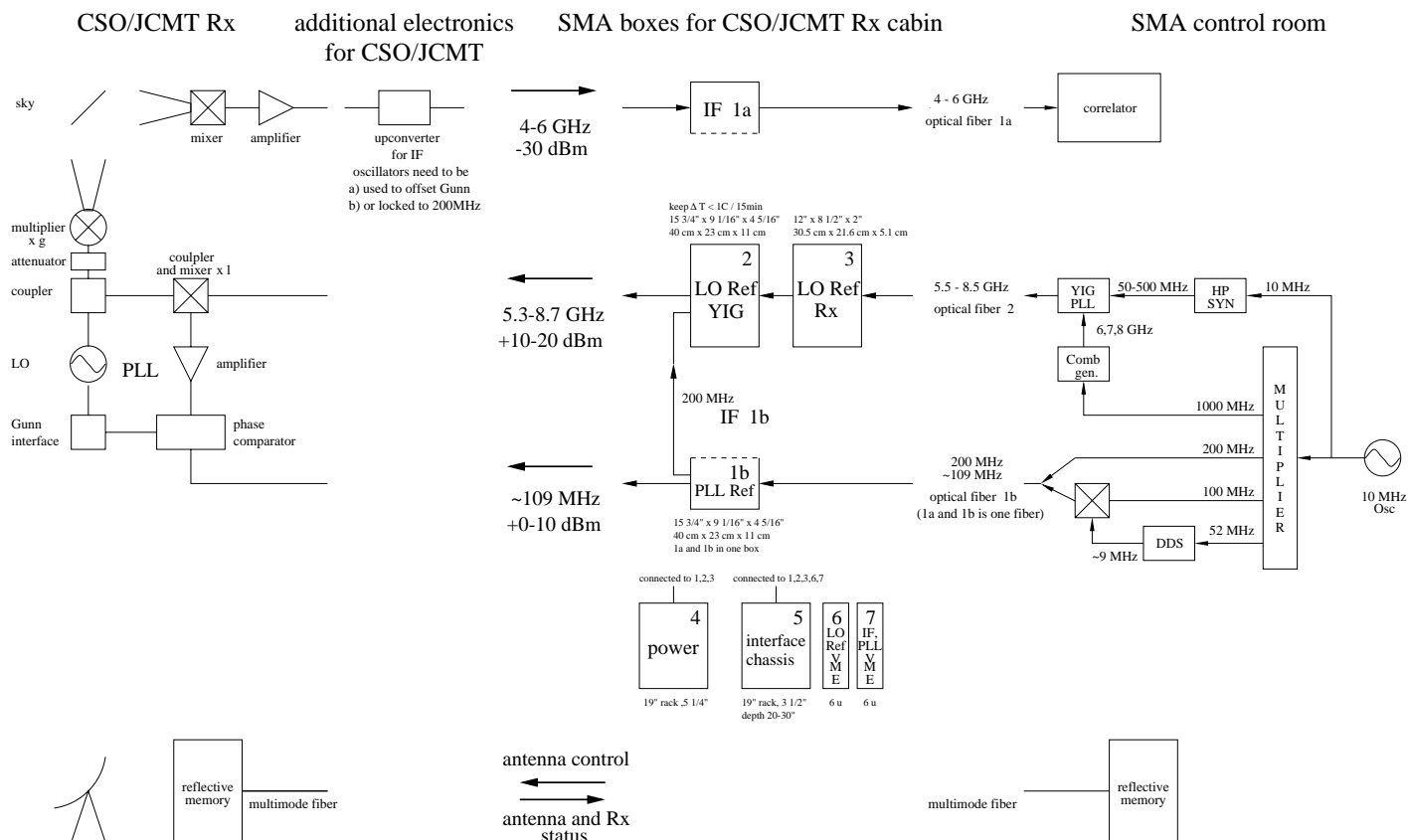

Figure 1: A layout of the electronics required to link the CSO and JCMT to the SMA. The sketch is divided into 4 parts: components of the CSO/JCMT receivers used for joint interferometry, additional electronics required by the CSO/JCMT to allow interferometry, electronics supplied by the SMA to connect CSO/JCMT to the SMA, electronics in the SMA control room relevant for the CSO/JCMT.

2.1.2 Software

Software will have to be provided to steer the CSO and the JCMT antennas from the SMA control room. Likely the commands will be at higher level such as “track this star” and CSO and JCMT will have to interpret these and translate them into a lower level command that moves the telescope. The CSO and JCMT antennas will have to allow an outside computer to steer them. The returned status report will need to be formatted in a way understandable to the SMA. Alternatively, one could think of steering the CSO and JCMT separately.

2.1.3 Telescope operator

For the JCMT an arrangement needs to be found concerning the role of the telescope operator. The current safety rule requires a telescope operator plus one additional person to be in the building when the JCMT is open. This means that there needs to be at least two observers during joint interferometer operation, one to accompany the JCMT operator when he needs to go to the JCMT, one to do the observations from the SMA control room. Alternatively, one could either allow the JCMT operator to assist from the SMA control room or to run the JCMT without an operator.

The CSO allows use of the telescope without anybody in the building.

2.2 Receivers

The joint interferometer will use as many of the current CSO and JCMT receivers as possible. However, some additional components will be needed and some modifications might be necessary.

2.2.1 Optical fibers

The JCMT and CSO should be linked by 3 optical fibers to the SMA control room. On one fiber the SMA control building will send an LO reference and a PLL reference to synchronize the receivers. The IF will be sent back to the correlator on a second fiber. We suggest to install a third spare fiber, which can either be used as a backup or for a second IF, for example from a two pixel array receiver.

telescope	ν GHz	IF GHz	Gunn GHz	multi. Gunn	LO ref. GHz, dBm	multi. LO ref.	PLL ref. MHz, dBm	PLL speed μ sec	date completed
SMA	176-256	4-6		$\times 2$	5.3-8.7, 0-20		~ 109 , 0-10	10	\checkmark
JCMT	211-269	3.1-4.9	71-92	$\times 3$	5.0-5.5		~ 100		\checkmark
CSO	180-280	1-2		$\times 3$	5.5-6.5, +5		20, -20		\checkmark
SMA	250-360	4-6		$\times 3$	5.3-8.7, 0-20		~ 109 , 0-10	10	\checkmark
JCMT	315-370	3.1-4.9	79-92	$\times 4$	5-5.5		~ 100		\checkmark
CSO	280-400	1-2		$\times 4$	5.5-6.5, +5		20, -20		\checkmark
SMA	400-520	4-6			5.3-8.7, 0-20		~ 109 , 0-10	10	
JCMT	430-510	3.1-4.9	72-85	$\times 6$	8-11		100-500		\checkmark
CSO	400-500	1-2		$\times 6$	5.5-6.5, +5		20, -20		\checkmark
SMA	600-720	4-6		$\times 6$?	5.3-8.7, 0-20		~ 109 , 0-10	10	~ 2000
JCMT	630-710	3.1-4.9	105-118	$\times 6$	8-11		100-500		\checkmark
CSO	600-725	1-2		$\times 6$	5.5-6.5, +5		20, -20		\checkmark
SMA	780-920	4-6			5.3-8.7, 0-20		~ 109 , 0-10	10	
JCMT									
CSO	780-950	1-2		$\times 6$	5.5-6.5, +5		20, -20		\checkmark

Table 1: Characteristics of the receivers of the CSO, JCMT and SMA. CSO and JCMT are planing to upgrade all their IFs to 4-6 GHz by 2001.

2.2.2 Observing frequencies

The SMA receivers will cover observing frequencies between 180 GHz and 920 GHz, the CSO covers the same range, but the JCMT can currently only observe between 211 and 710 GHz (see Tab. 1). However, the SMA high frequency receiver (780 - 920 GHz) is not expected to be installed at the telescopes until 2002. The JCMT might want to plan to install a similar receiver around the same time.

2.2.3 Bandwidth

The SMA receivers will have a bandwidth of 2 GHz, most of the CSO and JCMT receivers currently have a bandwidth of only 1 GHz. There are plans for wider IFs for the CSO and the JCMT receivers. Though a wider bandwidth is desirable, even a 1 GHz IF will allow lots of interesting observations.

2.2.4 IF frequency

The CSO, JCMT and SMA currently all have different intermediate frequencies (IF) (see Tab. 1). To allow correlation the IF frequencies need to be the same. Since the SMA provides the correlator and most of the receivers it seems easiest to change the CSO and JCMT IFs. CSO and JCMT plan to raise all their IFs to 4 - 6 GHz by 2001.

To allow interferometry in the near future we can

- operate only at 4 - 5 GHz and upconvert the CSO IF with a 3.0 GHz oscillator,
- operate at 4 - 6 GHz for all receivers except the CSO, which will require an upconversion of the JCMT IF as well as the CSO IF.

Note that an upconversion will also require

- a different LO frequency
- and that the oscillators used to offset the LO are coherent with the oscillators used to offset the IF.

Specific suggestions for upconversion are listed in Appendix 7.1.

2.2.5 Phase Lock Loop

For interferometry all Gunn oscillators need to be locked to a common oscillator, in our case a 10 MHz oscillator (see Fig. 1). The underlying 10 MHz is multiplied up to a common 200 MHz signal, a common signal at a few GHz and an individual DDS signal around 109 MHz, that is used for fringe tracking and that will also include the individual Walsh function (Fig. 1). These three signals are transmitted via optical fiber to each antenna. The SMA electronics, which will also be provided to the CSO and JCMT, will retrieve the signal from the fiber and clean the high frequency signal by locking it to a local YIG oscillator. The input to the receiver phase lock loop is the PLL reference at ~ 109 MHz and the LO reference between 5.3 and 8.7 GHz. The Gunn frequency (ν_{Gunn}) is the LO reference (LO_{ref}) multiplied by a factor l plus ¹ the ~ 109 MHz signal (PLL_{ref}). This Gunn frequency is multiplied by g to give the LO frequency (ν_{LO}).

$$\nu_{Gunn} = l \times LO_{ref} + PLL_{ref}, \quad (1)$$

$$\nu_{LO} = g \times \nu_{Gunn} \quad (2)$$

$$= g \times (l \times LO_{ref} + PLL_{ref}) \quad (3)$$

$$= g \times l \times LO_{ref} + g \times PLL_{ref}. \quad (4)$$

(The observing frequency is the LO frequency plus or minus the IF frequency.) The factor g and l are currently the same for each set of CSO and JCMT receivers, but unfortunately different for the SMA.

Here are three possible alternatives to create the same LO frequency in all receivers in spite of different multiplication factors g :

1. The SMA is designed to send out two different LO reference signals in order to allow dual frequency operation. If the joint interferometer observes at one frequency, one of the LO references could be used to lock the SMA Gunn and the second LO reference could be used to lock the CSO and JCMT Gunns. This requires, however, that the two LO references are locked to each other. (According to my information this is the case due to the common 10 MHz oscillator.)

¹We need to check that all of the PPL systems used add the PLL_{ref} rather than subtract it.

2. As long as the factor $g \times l$ is constant for all sets of receivers one could change the individual PLL reference so that $g \times PLL_{ref} = g' \times PLL'_{ref}$. However, at the moment the design only allows a change of the PLL_{ref} of a few MHz. To change the PLL reference by the necessary few tens of MHz a signal at a few tens of MHz has to be created to which the ~ 9 MHz DDS signal is added. (In the current scheme the ~ 9 MHz DDS signal is always added to 100 MHz, see Fig. 1.)
3. The CSO and JCMT could change their PLL to match the SMA PLL. It would not be too hard to take the SMA PLL design and build extra sets for the CSO and JCMT. However, new Gunn oscillators (~ 6000 \$ each) and new multipliers (~ 12000 \$ each) will probably be needed.

For scheme 1) and 2) we will need to test that the current phase comparators are fast enough to allow modulations due to the Walsh function. The PLL needs to have a settling time of less than $10 \mu\text{s}$.

2.2.6 Receiver tuning

It will be possible to tune the SMA receivers and JCMT's 230 and 350 GHz receivers remotely. However, it would be difficult to implement remote tuning for the CSO and the remaining JCMT receivers. At the moment we plan on manually tuning the CSO and JCMT receivers.

2.3 Polarization

At the CSO and the JCMT the receivers are attached to the primary mirror, at the SMA they only rotate in azimuth but do not move with elevation. In all cases the polarization of an astronomical object will rotate with respect to the receiver, however they will rotate differently. In comparison to CSO and JCMT, the polarization detected by the SMA receivers is additionally rotated clockwise by an angle equivalent to the elevation. (The SMA optics is shown on the web.) Since only radiation of the same polarization is coherent, one has to ensure that all receivers measure the same polarization. The following hardware would allow to select the same polarization:

1. **K-mirror:** This could be achieved by adding a K-mirror to the CSO and the JCMT. A K mirror is a tube containing is three flat mirrors

(which are arranged to look like the letter K). Linear polarization entering the tube at an angle ψ , will emerge from it at an angle of 2ψ . By turning the tube the polarization can be turned.

2. **Half wave plates:** Similarly half wave plates in transmission or in reflection can be used to rotate polarization.
3. **Quarter wave plates:** Alternatively, we could insert quarter wave plates at an angle of 45° in front of all receivers, so that all receivers are sensitive to circular polarization.

We have to correct for the different orientation of the quarter wave plates by adding a phase (which is a function of the elevation of the source). This correction can be applied by changing the DDS or by adding a phase during data reduction (see Appendix 7.2).

A quarter wave plate adds a 90° phase shift only at one particular frequency. At all other frequencies a linearly polarized wave will be transformed into an elliptically rather than a circularly polarized wave. Elliptical polarization can result in a loss in the correlated signal. However, the loss is smaller than 6% if we have one (and only one) quarter wave plate for each receiver (see Appendix 7.3).

The above mentioned hardware has the following advantages and disadvantages:

- Advantages of 1. and 2.: The device only needs to be installed at the JCMT and the CSO. The K-mirror is also frequency independent, whereas we would need a separate half wave plate for every receiver.
- Disadvantages of 1. and 2.: The K-mirror and the half wave plates needs to be mechanically turned by a computer which knows the elevation of the telescope. This is more complicated than a stationary quarter wave plate.

The K-mirror needs a parallel beam as input. At the CSO a K-mirror could be inserted in the parallel beam between the third and fourth or fourth and fifth mirror. There is no obvious place for a K-mirror at JCMT, extra optics would be required.

According to R. Akeson the systematics for polarimetry (see below) are generally lower if one cross correlates circular polarization.

2.4 Polarimetry

In principle it would be possible to do polarimetry with the CSO-JCMT-SMA interferometer independent whether we use a K-mirror, half wave plates or quarter wave plates. However, it may be necessary to measure the polarization in several steps, for the following two reasons:

1. Not all the receivers allow dual polarization measurements. Currently the CSO does not have any dual polarization receivers, the JCMT has dual polarization at 350, 450 and 690 GHz, the SMA antennas will have a dual polarization receiver at 350 GHz.

If we only have single polarization receivers, we can obtain the orthogonal polarization by adding a half wave plate at the correct angle or by turning the quarter wave plates by 90° . Many separate measurements are needed to correlate all combinations of polarizations.

2. The correlator capacity is finite. A careful analysis is still necessary to evaluate whether two polarizations of 10 antennas could be correlated at once and what bandwidth and resolution could be obtained.

If there is not sufficient correlator capacity, we could either use fewer antennas (e.g. add the JCMT and drop one of the SMA antennas) or time multiplex, i.e. first correlate some baselines and then others. It might be possible to save some computing power by assuming that the circular polarization is zero ($V = 0$) and by only taking three correlations on every baseline (to measure the I , U and Q Stokes parameters) instead of four correlations.

2.5 Transmitter

Experience with the CSO-JCMT interferometry showed that a transmitter at the observing frequency of the interferometer is very useful to debug the system since it sends out a strong signal and does not change its position. I suggest that we try to get our first fringes from a transmitter possibly installed on the roof of UKIRT (United Kingdom Infrared Telescope). SMA has a suitable transmitter that currently operates at a frequency up to 250 GHz, possibly up to 350 GHz.

3 Realization of technical outline

Table 2 summarizes the necessary tasks to enable CSO-JCMT-SMA interferometry. Experts suggested dates for the completion of tasks, which are included in the table.

The following areas will need some more detailed considerations:

- IF upconversion
- Phase lock loop
- Polarization
- Software to drive CSO and JCMT antennas from SMA control room and return of status report from CSO and JCMT to SMA
- A detailed list of tasks and time schedule
- Order of priorities
- Application for joint telescope time

4 Conclusion

By adding the CSO and JCMT to the SMA the collecting area as well as the resolution and u-v coverage will drastically increase at very low expense and effort. The higher sensitivity might prove essential for extragalactic observations, where sources are relatively faint at submillimeter wavelengths and could hardly be detected with the CSO-JCMT interferometer. In galactic astronomy the joint interferometer will allow easier detection of small faint objects such as proto stellar disks. If there are any polarization measurements the success will largely depend on the sensitivity of the interferometer. The project is feasible and should neither be very expensive nor very difficult. However, it needs some planing and some work. If we start putting some effort into the linking of the telescope now, ideally we could have a four element interferometer by the beginning of next year (2000) and a ten element interferometer by 2001.

	CSO	JCMT	SMA	
1) antennas	✓	✓	one	Jun 99
			two	Aug 99
2) optical fiber	Sep 99	Sep 99	✓ (between some an.)	
3) multimode fiber	Sep99	Sep 99	✓ (between some an.)	
4) reflective memory cards			✓ (for 3 antennas)	
5) antenna control from SMA				
6) electronics linking opt. fiber to Rx PLL	Aug 99	Aug 99		Aug 99
7) quarter wave plates or K-mirror				
CSO and JCMT only:			—	—
8) upconversion of IF	2001	2001	—	—
9) new PLL or software for separate LO ref.	—	—	—	—
SMA only:	—	—		
10) correlator (hardware)	—	—	3 first down converters	✓
	—	—	all first down con.	Jan 00
	—	—	5 second down con. (5×328MHz)	✓
	—	—	all second down con.	Jan 00
11) correlator (digital)	—	—	6 an. × 2 Rxs for 1GHz	May 99
	—	—	6 an. × 2 Rxs for 2GHz	Dec 99
	—	—	correlator finished	Dec 00
12) creating LO ref.	—	—		Jun 99
13) creating PLL ref.	—	—		Jun 99
14) transmitter for 345 GHz	—	—	testing	

Table 2: Necessary hard and software for the proposed interferometry between the CSO, JCMT and SMA. The dates are current best estimates for completion.

5 References

Thompson, A. R., Moran, J. M., Swenson, G. W. J. (1994). *Interferometry and Synthesis in Radio Astronomy*. Krieger Publishing Company.

6 Acknowledgments

Thanks to all colleagues who contributed in comments and discussion, in particular to Rachel Akeson, Per Friberg, Oliver Lay, Bill Snow, David Wilner, Bob Wilson and Ken Young (Taco).

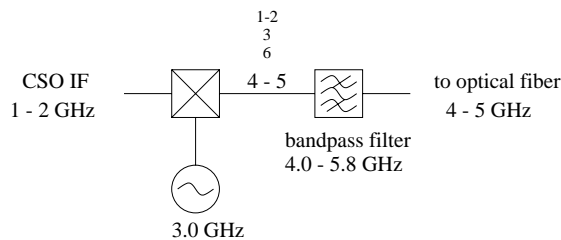

Figure 2: Suggested upconversion of the CSO IF.

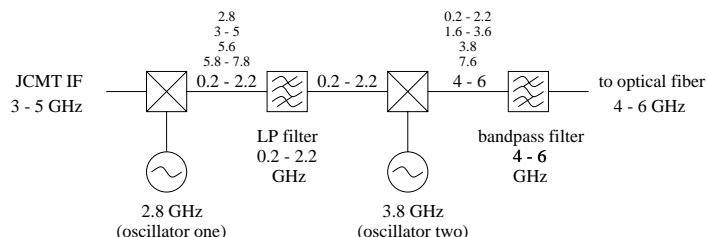

Figure 3: Down- then upconversion of JCMT IF (scheme 1).

7 Appendix

7.1 Specific suggestions for upconversion of CSO and JCMT IFs

To allow interferometry with the CSO, JCMT and SMA in the near future the CSO IF has to be upconverted and the JCMT may be upconverted. Here are some specific suggestions.

For the CSO I would suggest a simple upconversion with an oscillator followed by a bandpass filter, see Fig. 2. In case 1) (IF at 4-5 GHz) the oscillator would be at 3.0 GHz, in case 2) (IF at 5-6 GHz) I suggest 3.5 ± 0.164 GHz. (The 0.164 GHz ensure that only 3 of the 6 correlator blocks are used.)

The JCMT IF can't be upconverted in a single step, but will need a downconversion followed by an upconversion or vice versa. In the first case the first oscillator needs to be between 2.5 and 3.5 GHz, the second oscillator will obviously be 1 GHz higher than the first (see Fig. 3).

In the second case the first oscillator can be at exactly 3 GHz or 5 GHz, which would require quite sharp filters, or above 7 GHz (see Fig. 4). Table 3 lists some possible frequency values.

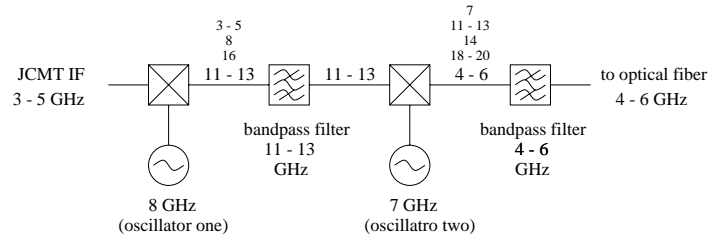

Figure 4: Up- then downconversion of JCMT IF (scheme 2).

Oscillator one GHz	Desired frequencies GHz	Undesired frequencies GHz	Oscillator two GHz	Desired frequencies GHz	Undesired frequencies GHz
3	6-8	0-2, 3, 3-5, 6	2	4-6	2, 4, 6, 6-8, 8-10
5	8-10	0-2, 3-5, 5, 10	4	4-6	4, 8, 8-10, 12, 12-14
7	10-12	2-4, 3-5, 7, 14	6	4-6	6, 10-12, 12, 16-18
8	11-13	3-5, 8, 16	7	4-6	7, 11-13, 14, 18-20
9	12-14	3-5, 4-6, 9, 18	8	4-6	8, 12-14, 16, 20-22
10	13-15	3-5, 5-7, 10, 20	9	4-6	10, 13-15, 20, 23-25

Table 3: Some possibilities to upconvert the JCMT IF from 3-5 GHz to 4-6 GHz. See also Fig. 4.

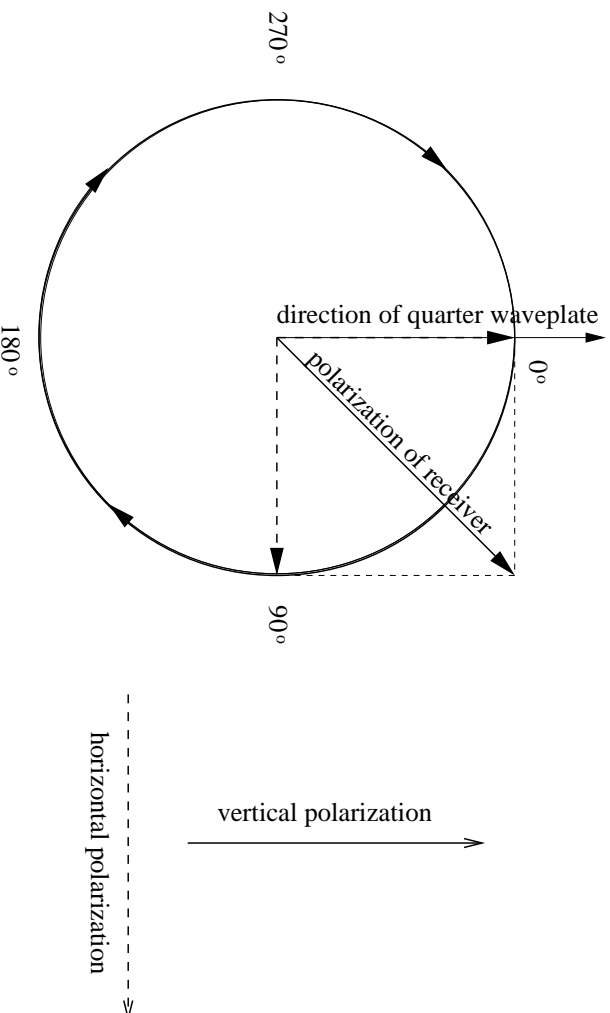

Figure 5: A linearly polarized wave is transformed into a circularly polarized wave when it traverses a quarter wave plate at 45° . (Here the direction of the quarter wave plate is defined to be parallel to the polarization of light that is retarded least.)

In both cases it should not be too difficult to put together an upconversion plate. The IF of the receiver in use would be (manually) connected to the input, the SMA optical fiber connector to the output.

7.2 Circular polarization

A quarter wave plate is made out of a material through which electromagnetic waves at one polarization propagate faster than electromagnetic waves at the perpendicular polarization. The thickness of the material is chosen to result in a difference of propagation time of $1/(4 \times \nu_{obs})$. A linear polarized wave at 45° to the quarter wave plate can be thought of as two equal components parallel and perpendicular to the fast propagation axis of the quarter wave plate. After traversing the plate one component precedes the other by 90° , the recombined wave is circular polarized. Fig. 5 tries to illustrate this.

Let's look from the receiver out onto the sky. The receiver is only sensitive

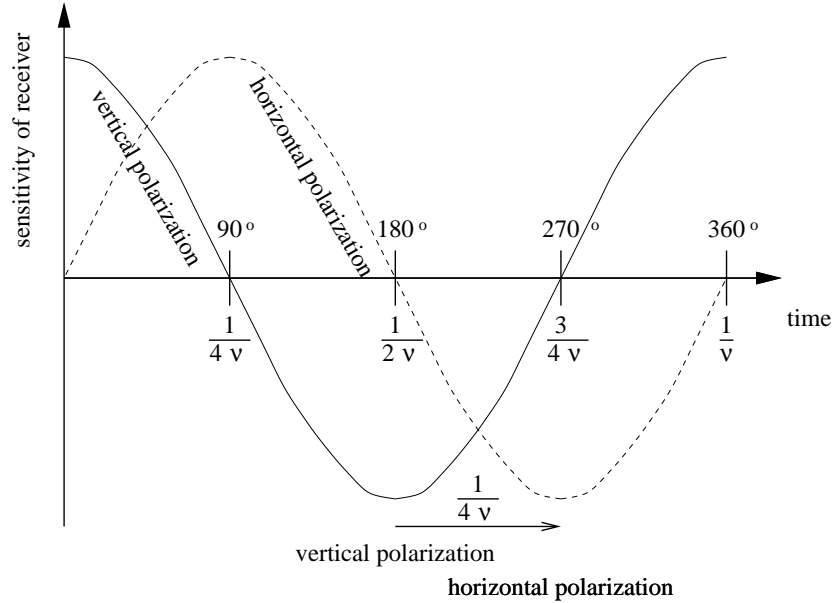

Figure 6: The response of the receiver with a quarter wave plate to a vertically and a horizontally polarized wave.

to one linear polarization due to the shape of the waveguide.² This linear polarization is transformed to a circular polarization after traversing the quarter wave plate. During one turn of the polarization vector, which will take the time $1/\nu$, the receiver will be sensitive to all possible directions of polarization. Fig. 6 shows the response of a receiver to a linearly polarized wave parallel to the direction of the quarter wave plate (here vertical). The receiver will also be sensitive to a linearly polarized wave perpendicular to the first (horizontal), however the highest sensitivity will be obtained at a time $1/(4 \times \nu)$ later.

Using the SMA antennas the 0° point of the circularly polarized wave rotates on the astronomical sphere according to the elevation angle (*elev*) of the telescope, at the CSO and JCMT it stays constant. In order to correlate the same polarization the CSO and JCMT signal need to be phase offset by the elevation angle. (The elevation of the source is

$$\sin(\text{elev}) = \sin \phi \times \sin \delta + \cos \phi \times \cos \delta \times \cos(15 \times HA), \quad (5)$$

²This is a slightly oversimplified statement. Most horns also couple with some orthogonal polarization, which is a problem for polarimetry.

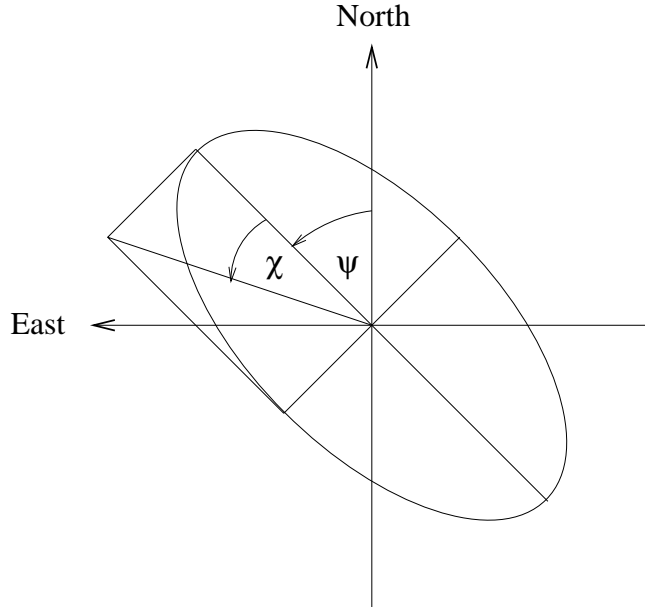

Figure 7: Definition of ψ and χ of elliptical polarization on the sky.

where ϕ is the latitude of the observatory, δ is the declination of the source and HA the hour angle of the source. Even in the CSO and the JCMT the polarization of a celestial source will rotate in the receiver as the earth turns. The parallactic angle η , which is the angle between a vector pointing to the celestial pole (constant angle to polarization of celestial object) and a vector pointing to the zenith (constant angle to polarization of receiver), describes this rotation:

$$\cot(\eta) = \frac{1}{\sin HA} \times [\cos \delta \frac{\sin \phi}{\cos \phi} - \sin \delta \cos HA]. \quad (6)$$

7.3 Interferometer response to polarization

As discussed above a quarter wave plate will introduce an extra optical path of $\lambda/4$ in one direction of polarization with respect to the other. When passing a linearly polarized wave of wave length λ' through the wave plate, the phase different of the two components will be different from 90° and the resultant wave will be elliptically polarized. The major axis of the ellipse is at 45° of the direction of the wave plate, the ratio of minor to major axis, depends on the wave length (see Fig. 7). Assuming we chose a quarter

wave plate for 223 GHz, we get an axis ratio of 0.71 ($\tan^{-1}(0.71) = 35^\circ$) for 176 GHz or for 269 GHz.

According to Thompson, Moran, Swenson (1986), the response of an interferometer when correlating a signal from antennas m and n is

$$r_{mn} = \frac{1}{2}G_{mn} \left\{ \begin{aligned} &I[\cos(\psi_m - \psi_n) \cos(\chi_m - \chi_n) + j \sin(\psi_m - \psi_n) \sin(\chi_m + \chi_n)] \\ &+ Q[\cos(\psi_m + \psi_n) \cos(\chi_m + \chi_n) + j \sin(\psi_m + \psi_n) \sin(\chi_m - \chi_n)] \\ &+ U[\sin(\psi_m + \psi_n) \cos(\chi_m + \chi_n) - j \cos(\psi_m + \psi_n) \sin(\chi_m - \chi_n)] \\ &- V[\cos(\psi_m - \psi_n) \sin(\chi_m + \chi_n) + j \sin(\psi_m - \psi_n) \cos(\chi_m - \chi_n)] \end{aligned} \right\}, \quad (7)$$

where G_{mn} is an instrumental gain factor,
 I, Q, U, V are the stokes parameters of the astronomical source,
 ψ the angle between the major axis of the elliptical polarization and celestial north,
 χ the inverse tangent of the axis ratio of the elliptical polarization.

For SMA antennas $\psi_m = \text{pralactic angle} + \text{angle of receiver} + \text{elevation}$, for JCMT/CSO $\psi_n = \text{pralactic angle} + \text{angle}'$ of receiver.

Using the same quarter wave plates ($\chi_m = \chi_n$) the correlation of the JCMT signal with the SMA signal yields:

$$r_{mn} = \frac{1}{2}G_{mn} \left\{ \begin{aligned} &I[\cos(\psi_m - \psi_n) + j \sin(\psi_m - \psi_n) \sin(\chi_m + \chi_n)] \\ &+ Q[\cos(\psi_m + \psi_n) \cos(\chi_m + \chi_n)] \\ &+ U[\sin(\psi_m + \psi_n) \cos(\chi_m + \chi_n)] \\ &- V[\cos(\psi_m - \psi_n) \sin(\chi_m + \chi_n) + j \sin(\psi_m - \psi_n)] \end{aligned} \right\}. \quad (8)$$

For circular polarization ($\chi_m = \chi_n = 45^\circ$) this simplifies to

$$r_{mn} = \frac{1}{2}G_{mn} \left\{ \begin{aligned} &I[\cos(\psi_m - \psi_n) + j \sin(\psi_m - \psi_n)] \\ &- V[\cos(\psi_m - \psi_n) + j \sin(\psi_m - \psi_n)] \end{aligned} \right\}. \quad (9)$$

A quarter wave plate will only introduce a 90° delay at a single frequency. Each receiver will need its own quarter wave plate. Even then depending on

the frequency the delay will lie between 70° and 110° and the resultant wave will be elliptical rather than circular ($|\chi| = 35^\circ$ to 45°). Assuming that random polarization, I , dominates Equ. 8 shows that the signal is reduced by at most $1 - \sin(2\chi) = 1 - \sin(70^\circ) = 0.06$ in the case in which the elliptical polarization of the JCMT receiver is perpendicular to the one at the SMA ($\psi_m - \psi_n = 90^\circ$).

7.4 Quarter wave plates

According to Rachel Akeson OVRO uses quarter wave plates consisting of a wound wire grid in parallel to a mirror for polarimetry. The distance between the mirror and the grid can be adjusted for the observing frequency. It is, however, difficult to measure this separation to the accuracy required.

BIMA uses grooved dielectric plates for their quarter wave plates. These are not as flexible, but much easier to use and have low instrumental polarization. Cutting the grooves might be difficult at frequencies above 250 GHz.

There are also quarter wave plates made from quartz. They require a special coating to minimize reflection.